

# Husbandry Guidelines

## Greater Stick-nest Rat



Scientific Name:  
*Leporillus conditor*

Compiled by Jenny Procter  
Alice Springs Desert Park  
September 2007

<b>1</b>	<b>TAXONOMY .....</b>	<b>4</b>
1.1	NOMENCLATURE .....	4
1.2	SUBSPECIES .....	4
<b>2</b>	<b>NATURAL HISTORY .....</b>	<b>5</b>
2.1	MORPHOMETRICS .....	5
2.1.1	<i>Mass and Basic Body Measurements</i> .....	5
2.1.2	<i>Sexual Dimorphism</i> .....	5
2.1.3	<i>Distinguishing Features</i> .....	5
2.2	DISTRIBUTION AND HABITAT .....	6
	( <a href="http://www.wildliferesearchmanagement.com.au/gsnr.htm">HTTP://WWW.WILDLIFERESEARCHMANAGEMENT.COM.AU/GSNR.HTM</a> ) .....	6
2.3	CONSERVATION STATUS .....	6
2.4	DIET IN THE WILD .....	7
<b>3</b>	<b>HOUSING REQUIREMENTS.....</b>	<b>8</b>
3.1	EXHIBIT/ENCLOSURE DESIGN .....	8
3.2	SPATIAL REQUIREMENTS .....	8
3.3	ENCLOSURE FURNISHINGS .....	8
<b>4</b>	<b>GENERAL HUSBANDRY .....</b>	<b>10</b>
4.1	HYGIENE AND CLEANING .....	10
<b>5</b>	<b>FEEDING REQUIREMENTS .....</b>	<b>11</b>
5.1	CAPTIVE DIET .....	11
5.2	SUPPLEMENTS .....	11
5.3	PRESENTATION OF FOOD .....	11
<b>6</b>	<b>HANDLING AND TRANSPORT .....</b>	<b>12</b>
6.1	TIMING OF CAPTURE AND HANDLING .....	12
6.2	CAPTURE AND RESTRAINT TECHNIQUES .....	12
6.2.1	<i>Restraint Grip</i> .....	12
6.3	RELEASE .....	13
6.4	TRANSPORT REQUIREMENTS .....	13
6.4.1	<i>Box Design</i> .....	13
6.4.1.1	<i>Box Diagram</i> .....	13
6.4.2	<i>Furnishings</i> .....	14
6.4.3	<i>Water and Food</i> .....	14
6.4.4	<i>Animals per Box</i> .....	14
6.4.5	<i>Timing of Transportation</i> .....	14
6.4.6	<i>Release from Box</i> .....	14
<b>7</b>	<b>HEALTH REQUIREMENTS .....</b>	<b>15</b>
7.1	DAILY HEALTH CHECKS .....	15
7.2	ROUTINE TREATMENTS .....	15
7.3	KNOWN HEALTH PROBLEMS .....	15
7.4	QUARANTINE REQUIREMENTS.....	15
<b>8</b>	<b>BEHAVIOUR.....</b>	<b>17</b>
8.1	ACTIVITY .....	17
8.2	SOCIAL BEHAVIOUR.....	17
8.3	BEHAVIOURAL PROBLEMS .....	17

8.4	SIGNS OF STRESS .....	17
8.5	BEHAVIOURAL ENRICHMENT .....	17
8.6	INTRODUCTIONS AND REMOVALS .....	18
8.7	INTRASPECIFIC COMPATIBILITY .....	18
8.8	INTERSPECIFIC COMPATIBILITY.....	19
<b>9</b>	<b>BREEDING.....</b>	<b>20</b>
9.1	REPRODUCTIVE CONDITION .....	20
9.1.1	<i>Females</i> .....	20
9.1.2	<i>Males</i> .....	20
9.2	TECHNIQUES USED TO CONTROL BREEDING .....	20
9.3	AGE AT FIRST BREEDING AND LAST BREEDING .....	20
9.4	ABILITY TO BREED EVERY YEAR.....	20
9.5	ABILITY TO BREED MORE THAN ONCE PER YEAR .....	20
9.6	NESTING, HOLLOW OR OTHER REQUIREMENTS.....	20
9.7	BREEDING DIET.....	21
9.8	OESTROUS CYCLE AND GESTATION PERIOD .....	21
<b>10</b>	<b>ARTIFICIAL REARING .....</b>	<b>22</b>
10.1	HOUSING .....	22
10.2	TEMPERATURE REQUIREMENTS .....	22
10.3	DIET AND FEEDING ROUTINE .....	22
<b>11</b>	<b>ACKNOWLEDGEMENTS .....</b>	<b>23</b>
<b>12</b>	<b>REFERENCES .....</b>	<b>24</b>
<b>13</b>	<b>BIBLIOGRAPHY.....</b>	<b>25</b>
<b>14</b>	<b>APPENDIX.....</b>	<b>27</b>
14.1	STOCKLIST .....	27

# 1 TAXONOMY

## 1.1 Nomenclature

Scientific Name: *Leporillus conditor* (builder little-hare)  
(Sturt, 1961)

Pronunciation: lep'-or-il'-us kon'-dit-or

Recent Synonyms: *Leporillus jonesi*

Common Name: Greater Stick-nest Rats

Other Names: House-building Rat, Large Stick-nest Rat, Stick-nest Rat, Franklin Island Stick-nest Rat, Franklin Island House-building Rat

### Classification

Class	Mammalia
Order	Rodentia
Family	Muridae
Subfamily	Hydromyinae
Tribe	Conilurini
Genus Species	Leporillus conditor

## 1.2 Subspecies

None

## 2 NATURAL HISTORY

The Greater Stick-nest Rat is a rodent species which lived in the semiarid and southern arid parts of Australia. Their name is derived from the distinctive stick nests that the species build for shelter from harsh conditions and predators. Prior to European settlement this species as well as the Lesser Stick-nest Rat were common on the Australian mainland and a few coastal islands ([www.environment.sa.gov.au/biodiversity/sticknestrat](http://www.environment.sa.gov.au/biodiversity/sticknestrat)). In the 19<sup>th</sup> century Stick-nest Rats were greatly affected by the establishment of rabbit, sheep, cattle, fox and cat populations. By the mid 19<sup>th</sup> century both species were presumed to be extinct on the mainland, with only a small population of Greater Stick-nest Rats surviving on Franklin Island in South Australia ([www.environment.sa.gov.au/biodiversity/sticknestrat](http://www.environment.sa.gov.au/biodiversity/sticknestrat)).

In the 1980s studies undertaken by Read (1984) and Copley (1988) detailed the population dynamics and behaviour of the remaining population of Greater Stick-nest Rats. These studies initiated the production of a species recovery plan by the Australasian Species Management Program (ASMP) that targeted the maintenance of the existing population, establishing a breeding colony and increasing wild populations. Through this program areas including Salutation Island (Western Australia), Reevesby Island, St Peters Island and Roxby Downs (South Australia), were identified as suitable areas for their translocation. Successful pest management and translocation enabled these areas to be developed into suitable environments capable of maintaining stable and healthy populations. For further information on the reintroduction program see section 5.3.

Captive populations have been preserved via an ASMP studbook, which has allowed individual specimens to be held for public education and a greater knowledge into the biology of this species.

### 2.1 *Morphometrics*

#### 2.1.1 **Mass and Basic Body Measurements**

Head/body length *	170g – 260g
Tail Length *	145g – 180g
Weight *	180g – 450g
ASDP average female weight (n = 21)	307g (± 45g)
ASDP average male weight (n = 17)	311g (± 135g)

(\* Strahan , 1995)

#### 2.1.2 ***Sexual Dimorphism***

There is no obvious sexual dimorphism present in the Greater Stick-nest Rat. Females have 4 teats on their underside positioned in the abdominal region. As with most rodent species, there is sexual dimorphism in ventricular distances, with the males ventricular distance being larger than the females.

#### 2.1.3 ***Distinguishing Features***

The Greater Stick-nest Rat is distinguished firstly by its large size and then by the yellowish-brown to grey fur above and creamy white fur below. Their hind feet have

distinctive white markings on their upper surface. They have long ears, large eyes and a blunt snout. Their tail is usually evenly furred, dark brown above and light brown below. Generally they rest on their hind feet in a hunched position (Strahan, 1995). These features distinguish the Greater Stick-nest Rat from all other species making it easily recognizable in the wild.



([www.sharkbay.org/jpg\\_images/sticknest\\_rat.jpg](http://www.sharkbay.org/jpg_images/sticknest_rat.jpg))

## 2.2 Distribution and Habitat



(<http://www.wildliferesearchmanagement.com.au/gsnr.htm>)

The Greater Stick-nest Rat is known to inhabit semi-arid to arid scrubland where there is little or no freshwater

([www.calm.wa.gov.au/plants\\_animals/pdf\\_files/sp\\_greater\\_stick-nest\\_rat.pdf](http://www.calm.wa.gov.au/plants_animals/pdf_files/sp_greater_stick-nest_rat.pdf)).

## 2.3 Conservation Status

ASMP Category

Category: 3 No regional Management Plan

IUCN Category

Category: Endangered A1c (Decline in area of occupancy, extent of occurrence and/or quality of habitat.)

Environment and Protection Biodiversity Conservation Act 1999

Classification: Threatened (Vulnerable)

Western Australia Wildlife Conservation Act

Classification: Threatened with sub regional extinction.

## **2.4 Diet in the Wild**

In released populations in South Australia the Greater Stick-nest Rat has shown to eat predominately native succulents, herbs, fruits, berries, seeds and introduced grasses (Copley, 1999). The Greater Stick-nest Rat has shown to adapt to different environments very successfully depending on the availability of food sources within the area it inhabits. Reevesby Island has a large history of agriculture and therefore mainly dominated with grasslands. In this area the Greater Stick-nest Rat has altered its diet to eat a higher proportion of grasses (Ryan *et. al.*, 2003). Traces of invertebrate life have been seen during faecal analysis however this could be due to accidental consumption (Copley, 1999).

Faecal analysis from the mainland have shown more diversity of diet including smaller rodents, invertebrates and well as a greater variety of plants species (Ryan *et al.*, 2003).

## **3 HOUSING REQUIREMENTS**

### **3.1 Exhibit/Enclosure Design**

At the Alice Springs Desert Park (ASDP) the Greater Stick-nest Rats are housed in 3 different types of enclosures: nocturnal exhibit, open air exhibit and holding enclosures.

The nocturnal exhibit is a fully enclosed indoor display with a concrete base and glass frontage for viewing by park visitors. Glass is also used to separate this exhibit to the exhibit adjacent. Access to the exhibit is through a self closing door at the rear of the exhibit which is flush with the back wall and can therefore not be seen by visitors. The exhibit is ventilated and cooled in warm conditions with an evaporative cooling air conditioning unit set at approximately 27°C.

The open air exhibit is shared with a variety of bird species. It is fully enclosed with 12mm<sup>2</sup> galvanized wire mesh with a concrete footing around the perimeter at a depth of 600mm. On one side of the exhibit there is a concrete wall, 100cm high, with glass above it to allow visitors easy viewing of the exhibit. Entry into the exhibit is through an air lock on the side, out of the public view. The exhibit is fitted with a fine spray sprinkler system that can be put on an automatic timer during periods of high heat.

The holding enclosures are also outdoors and are surrounded by 12mm galvanized wire mesh attached to a sloped concrete base with a drainage pipe at the lowest point. A 400-500mm high tin skirt should surround the enclosure to prohibit animals from climbing the walls and to reduce aggression between enclosures. Each enclosure is covered partially with a corrugated iron roof for protection from extreme weather conditions and to provide sunny and shady areas. Like the open air exhibits they are fitted with a fine spray/mist sprinkler system operated on a timer.

### **3.2 Spatial Requirements**

Greater Stick-nest Rats have a minimum enclosure size of 200cm<sup>2</sup> per individual to allow for a large enough space for nest building (Jackson, 2003). Enclosures larger than this are preferred as it has been shown to increase activity levels and reduce aggression in a group. For each additional animal an area of 100cm<sup>2</sup> must be added to the minimum enclosure size.

### **3.3 Enclosure Furnishings**

Enclosure furnishings will depend on whether the exhibit is in public view or not. All enclosures however must be provided with browse on a daily basis for nest building and enrichment. This is particularly important for groups containing females as they are the main nest builders.

In the wild, the Greater Stick-nest Rat has been known to prefer habitats with a moderate amount of under storey. A study done by Moseby & Bice (2004) indicated this preference may be due to shelter from predators as well as increased food availability. In captivity due to the lack of predators and high food resources available large amounts of cover do not need to be provided. However it is recommended that in open areas there should be available hides for them to escape and retreat too if threatened or nervous.

In the nocturnal enclosures a fine scree, of approximately 150mm deep, is used as a substrate with *Acacia kempeana* (Witchetty Bush) and *Acacia estrophiolata* (Ironwood) as the main vegetation. Mulch is added underneath each tree to create a naturalistic look and allow foraging behaviours. For browsing purposes grasses need to also be included. At ASDP we use *Triraphis mollis* (Purple Plume Grass) and *Enneapogon avenaceus* (Native Oat Grass) as the dominant species. Other species that can be used include *Enneapogon polyphyllus* (Woolly Oat Grass), *Aristida Arida*, *Themeda triandra* (Kangaroo Grass), *Enteropogon acicularis* (Curly Windmill Grass) and *Eriachne mucronata*. Within the enclosures sandstone rocks and hollow logs are placed on the ground as well as secure vertical perching. These furnishings aid in enhancing the naturalistic look of the exhibit as well as providing the animals with objects to climb on and hide in.

In the open air exhibit a substrate of screed dirt is used with furniture requirements being very similar to that of nocturnal displays.

As the holding enclosures are not on public display many of the natural furnishings are not required. The substrate is a coarse sand of approximately 50mm deep. These enclosures have sandstone rocks placed around the enclosure with browse scattered within the enclosure as the vegetation. All rocks should be sunken to the concrete base to reduce potential injuries to animals if dislodged. Due to the lack of cover in the exhibit it is important to also add furniture for which the animals can run and hide underneath such as bin halves, lids and multiple nest boxes.

## **4 GENERAL HUSBANDRY**

### **4.1 *Hygiene and Cleaning***

Every day the following check list should be followed:

- Food bowls removed and cleaned
- Water dishes scrubbed and refilled
- Substrate should be raked or spot cleaned every few days
- Furniture such as rocks and logs should be scrubbed once a week.
- Browse should added ad lib and completely replaced every few days.
- Each animal should be visualized daily (depending on presence of young) to ensure they are in good health.
- Enclosures should be visually checked for any signs of injuries or stress to the animal (e.g. blood, diarrhea, fur clumps, etc.)
- New food should be placed, beneath a shelter, as late in the day as possible for all external exhibits or at the beginning of the night period in a nocturnal exhibit.

## **5 FEEDING REQUIREMENTS**

### **5.1 *Captive Diet***

The Greater Stick-nest Rat is herbivorous and is provided with a mix of freshly cut vegetables and seed every day. The Alice Springs Desert Park provide 25 grams of vegetable mix and 20 grams of budgie or small parrot mix per individual. The vegetable mix consists of chopped up sweet potato, peas, corn, carrot, lettuce, apple, broccoli and cauliflower. A 10cm length of salt bush is provided every second day. Each enclosure is also provided with fresh water daily. These diets will vary depending on group dynamics, animal health and weight. During the breeding season Alice Springs Desert Park increases the food gradually in 10 gram increments for pregnant or lactating females in order to ensure maximum breeding requirements are met. A varying diet for breeding and non-breeding is not required.

In large groups it may be necessary to provide different areas for feeding in order to reduce competition for resources; this is dependent on the social structure of the group. This should be closely monitored however as it may cause an increase in instability within the hierarchy.

### **5.2 *Supplements***

The vegetable mix provided is dusted with Calcium and Vitamin E powder at a rate of approximately 2mg per animal daily (see Appendix 1).

### **5.3 *Presentation of Food***

Food is presented in plastic bowls that are then placed beneath a cover, such as half a bin or lid. Any browse can either be given with the food bowl or placed anywhere in the exhibit.

## 6 HANDLING AND TRANSPORT

### 6.1 *Timing of Capture and Handling*

When catching Greater Stick-nest Rats the preferred time is as early or late in the day as possible, depending on reason for capture. During warmer months this can be particularly important as it will reduce the animal's exposure to extreme temperatures during the day. It is also important to try and follow the animal's natural activity levels. By catching the animal late in the day you will be releasing it back into the enclosure closer to the time it would naturally be active and therefore reducing the stress upon reintroduction into the enclosure.

### 6.2 *Capture and Restraint Techniques*

Greater Stick-nest Rats can be easily flushed out of nests by lifting the nest up from the base. Once out of the nest they will generally run along the perimeter of the enclosure towards an alternative nesting site. The technique used to capture these animals is to place a hand net flat to the ground against the perimeter of the enclosure and flush the animal towards the net with the other hand. Once the animal has passed onto the net the front edge is lifted first so that the animal will run straight into the net. Once in the net the animal should be secured quickly to prevent them from climbing out. The animal can then be transferred into a cloth bag (with a tie at the top) for health checks and weighing. Transferring the animal can be done in a variety of ways. The main technique used at the Alice Springs Desert Park is to use a flat hand (with a bag inverted bag over the top) to restrain the animal from above. Once the animal is restrained the bag can then be inverted over the animal and removed from the catching net. The bag is then tied and ready for either weighing or examination.

In order to catch an animal in a nest box it is easiest to contain them by blocking the entrance holes to the box. Then by directing the animal into the corner you can use the same technique used to remove an animal from a catching net.

They can then be transferred from a catching bag to a transport box or another bag using a pincer grip across the back of the shoulders as shown in 6.2.1. Due to the stress involved in handling it is always recommended that this be done as quickly as possible.

#### 6.2.1 *Restraint Grip*



## 6.3 Release

Due to the decline in Greater Stick-nest Rat numbers, the recovery plan has included various releases into a wide variety of areas. Success of release programs seems to be very closely correlated with presence of introduced predators as well as native predators (Richards *et al.*, 2001).

From 1985 to 1990, Reevesby Island saw an extensive feral predator eradication program in preparation for the release of various native mammals, including 101 Greater Stick-nest Rat. Current estimates for this population range between 1,000 and 5,000 individuals (<http://www.environment.sa.gov.au/biodiversity/sticknestrat.html>). This program is considered to be the most successful of all the releases done to date. More recent releases done on St Peter Island and at Roxby Downs have not experienced the large increase in population numbers seen at Reevesby. The presence of native predators such as Tiger Snakes and Goannas are considered to be the main factor restricting the population growths within these areas (<http://www.environment.sa.gov.au/biodiversity/sticknestrat.html>).

The first mainland re-introduction of Greater Stick-nest Rats was within a vermin-proof fenced area at Roxby Downs which has shown a peak in population numbers over winter and then a die off in the summer months possibly due to an increase in the ambient temperature (<http://www.aridrecovery.org.au/modules/content/index.php?id=12>).

## 6.4 Transport Requirements

### 6.4.1 Box Design

Greater Stick-nest Rats should be transported in boxes made from lined wood, fiberglass or fibreboard. Boxes should be 250cm<sup>2</sup> per individual with a height of at least 15cm. Air holes should be apparent on all four sides and top of the box with wire mesh over the top of these holes to stop the animals' feet and tail from protruding during transport. All joints must be made with strong, non-toxic water resistant glue. The inside of the box must be smooth without any sharp edges. The lid must fit the box closely and be sufficiently secured down with screws. Spacer bars should be present on both ends at the corners to prevent loss of air flow if boxes are stacked (IATA, 2007)

#### 6.4.1.1 Box Diagram

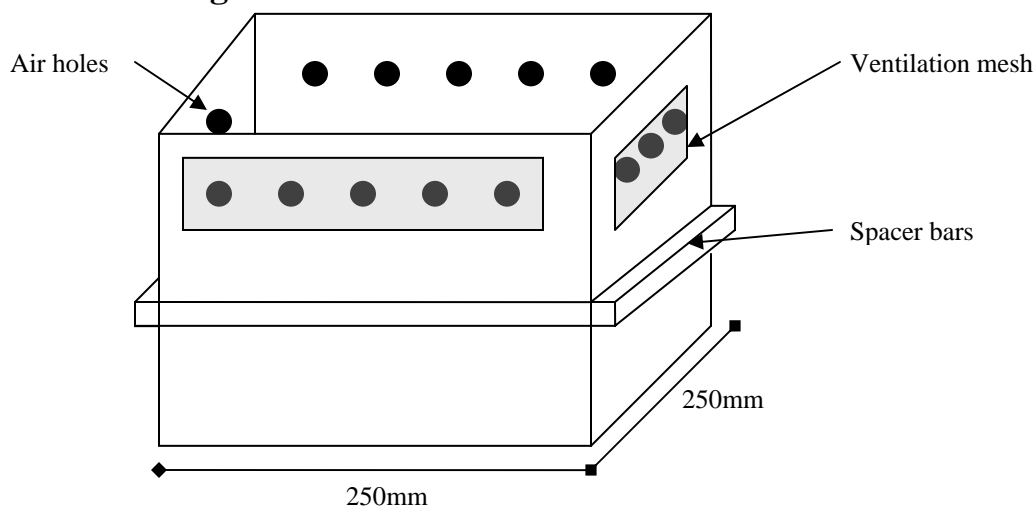

### **6.4.2 Furnishings**

Each individual should be provided with a layer of absorbent non-consumable bedding material such as shredded paper or wood wool.

### **6.4.3 Water and Food**

To supply water during travel a dampened cloth or wheat can be used for trips longer than 8 hours. For trips longer than 24 hours additional food and water should be supplied. In these cases food can be provided by placing a small amount of seed or finely chopped fruit or vegetable in the transport box. Subcutaneous fluids should be administered prior to animals being boxed to increase electrolyte levels which aids in dealing with the physical side effects of stress seen during animal movements.

### **6.4.4 Animals per Box**

Boxes can be made with several compartments to house numerous animals. It is not suggested to place more than one individual within the same compartment due to aggression and the stress of transport. For short trips each animal is individually held for transport in a calico bag, and then placed in a depression in the box substrate. On longer trips the individual would have free movement and access to food and water.

### **6.4.5 Timing of Transportation**

Greater Stick-nest rats can be transported at any time of the day however there should be close monitoring of the ambient temperatures. Animals should not be sent during times of extreme temperatures in excess of 25°C.

### **6.4.6 Release from Box**

Care should be taken when opening the transport box as individuals may have chewed through any cloth bag and become startled when the lid is removed. Animals should be inspected upon arrival to ensure no injuries were obtained during transportation and then released into a quarantine enclosure.

## 7 HEALTH REQUIREMENTS

### 7.1 Daily Health Checks

During morning rounds, when enclosures are being cleaned and replenished, each animal is sighted taking care to note that no injuries to the body or secretions from the eyes, ears or mouth are present. For females with young it is recommended that they have minimal disturbance until the young are older and more independent. Faeces should also be looked at to ensure that consistency and volume is normal. Location within the enclosure of each individual will also indicate the current social dynamics of the group/pair.

### 7.2 Routine Treatments

At ASDP routine faecals are done every 6 months or as required with the appropriate treatments following. Preventative treatments are also carried out at this time as well as opportunistically when internal movements or introductions are being done.

### 7.3 Known Health Problems

At the Alice Springs Desert Park previous Greater Stick-nest Rats have show the following health problems:

<b>Problem</b>	<b>Associated with</b>
Heat Stroke	Stress, high ambient temperatures, capture period
Conjunctivitis	Injury to eye, foreign matter (dirt/dust)
Tail Degloved	Poor handling, aggressive interactions, incidental injuries.
Abscess	Injuries (bites), puncture wounds
Infection of exposed tail tip after amputation	Secondary infections, chewing of stitches
Pancreatic Tumor	Age
Heavy Mouth Breathing (no apparent problems with lungs etc.)	Stress, high ambient temperatures, obesity
Kidney Failure	Stress, hypovolemic shock
Broken Leg	Poor handling, incidental injuries
Gastroenteritis	Stress, poor husbandry, age
Cardiac Contusion	Stress, age
Urinary Tract Infections	Stress, inadequate diet, age
Cataracts	Age related, genetics related

### 7.4 Quarantine Requirements

All animals that come to Alice Springs Desert Park have to go through a period of quarantine. This will include being housed in a separate enclosure to current captive stock, usually within the veterinary area. All plant material and left over food must be placed in the quarantine bin and disposed of without contact to other animals housed within the facility. Whilst in the enclosure all staff must use boot covers and a foot bath when entering and exiting. After any person comes in contact with food scraps and

faeces of the animals they must wash their hand using the approved Avisafe© before coming into contact with food or other animals (see Appendix 1).

Veterinary requirements within the period of quarantine include the following:

- Minimum quarantine period is 45 days for mammals, a vet examination with clearance.
- 3 x faecal flotation and wet preparations, a week apart with last two negative
- 2 x treat external parasites with Friskies™ Pyrethrins Flea Powder (see Appendix 1) on arrival and at next 10 day weigh in.
- Full clinical examination - including health screen, hair sample collection, sex determination and permanent identification (ear notching, microchip, photography, physical characteristics etc.).

## **8 BEHAVIOUR**

### **8.1 Activity**

The Greater Stick-nest Rat is generally nocturnal but has been seen out of the nest during dusk and dawn periods. During the night they will become very active, foraging for food, collecting material for nest building and confirming social dynamics through grooming, scent marking and general interactions. They are very inquisitive animals and will actively investigate their surrounds, particularly new objects and smells. During the night they can be seen resting on top of the nest or on the ground close to the nest. They can be easily startled and will retreat to the safety of the nest if feeling threatened or nervous.

### **8.2 Social Behaviour**

Due to the communal living situation they have been known to be aggressive towards other unknown Greater Stick-nest Rats as well as any other animals. They have a distinct hierarchy within their group, with the oldest female usually being the dominant animal. Males are also on a separate hierarchal order, positioned below the females' hierarchy order. Like the females it will usually be dominated by age and experience.

### **8.3 Behavioural Problems**

Greater Stick-nest Rats have shown behavioural problems such as aggression and excessive allogrooming. Excessive aggression can be caused by a variety of things but some of the main causes noted at Alice Springs Desert Park are the lack of browse for nest building, competition for resources or stimulation, the carrying capacity exceeding the size of the enclosure and the group composition. The need for natural dispersal also needs to be taken into consideration in relation to group composition and enclosure carrying capacity.

Introducing new individuals can be quite stressful and cause aggression, excessive allogrooming or even death within a group. This should be overseen by an experienced keeper.

### **8.4 Signs of Stress**

- Over grooming and excessive allogrooming
- Fur Loss
- Aggression
- Suppression
- Lack of interest in food
- Runny/ non-formed faeces
- Location within an enclosure

### **8.5 Behavioural Enrichment**

- Browse
- Scents
- Objects
- Food Presentation
- Sounds

## 8.6 *Introductions and Removals*

When introducing new animals it is important to monitor each one closely as they are very sensitive to changes and have been known to drop dramatically in weight after the first introductions during the acclimatisation period, which in a rodent this size can be up to a week. Prior to an individual animals release into a new enclosure, Baxters™ 0.9% sodium chloride fluids (see Appendix 1) is administered subcutaneously at a rate of approximately 1-4cc per individual to provide a supplementary boost of fluids to assist in reducing stress and the effect of blood composition changes on the liver at this point in time.

Before any introductions take place it is important to create an awareness between individuals, this is achieved by swapping individuals and enclosure furniture between enclosures over a period of time. See time line below.

Introduction timeline:

Day 1 Exchange individuals and furniture into the other individuals' enclosure.



Day 7 Return individuals and furniture back into their own original enclosure.



Day 14 Male/Female introductions – Move some of the males' furniture into the females' enclosure.



Day 16 Move Male into the females enclosure with his remaining furniture and monitor closely.



Day 18 If compatible begin removal of males' furniture to reduce clutter in the enclosure.

**NB:** Time periods should be examined and altered according to behaviour and response of individuals.

At the time of initial introduction close monitoring is required to ensure compatibility and minimal aggression. Minor injuries such as bite wounds or fur loss can be evident. If aggression is being displayed with injuries increasing and becoming more acute, then animals should be separated, and any injuries treated with antibiotics. After treatments are completed and the animal's health is clear, then the introduction process must start from the beginning again. Some animals may never accept another individual and alternative stock may be required. The Curator and Studbook keeper for this species will advise on the required actions to be undertaken.

## 8.7 *Intraspecific Compatibility*

As explained previously Greater Stick-nest Rats can be quite aggressive towards new individuals to a group as they find their place within the hierarchical order. In the wild as individuals become older they would naturally disperse. In captivity it has been

noted that some individuals will start to challenge more dominant individuals, depending on their age, causing aggression to quickly escalate. Displacement and suppression due to age or the removal of individuals may initiate bouts of aggression for the hierarchical positions. Any introduction of new individuals to a group requires a breakdown of the hierarchy, with gradual introductions of subordinate individuals building up to dominant animals as outlined in 8.2 and 8.6.

### **8.8 *Interspecific Compatibility***

At Alice Springs Desert Park Greater Stick-nest Rats are housed with a variety of species including large skinks and various avian species. It is also noted that they can be housed with other smaller rodent species that fill different niche requirements within the environment, as long as they do not compete for space and resources. Stick-nest Rats can be housed with a host of other species e.g. Owlet Nightjars, Gidgee Skinks, Cuckoo-shrikes, Babblers and small carnivores.

## **9 BREEDING**

### **9.1 Reproductive Condition**

#### **9.1.1 Females**

Females coming into reproductive condition will undergo teat development. Urine analysis can also be used to determine oestrus and cycle in females. An increase in nest building has also been observed prior to breeding season. This increase in activity also heightens territoriality of individuals.

#### **9.1.2 Males**

Males may be observed to have swelling of the genitalia when in the vicinity of a receptive female. However this physical change has also been noted with changes in temperatures so can not be used conclusively. Like the females, males can become more territorial during breeding seasons.

### **9.2 Techniques Used to Control Breeding**

At Alice Springs Desert Park separation is used to control breeding in Greater Stick-nest Rats. All young males are removed from their mothers before reaching reproductive maturity and only introduced to females that are suitable and required for breeding. They can produce up to 4 young per litter however 1-2 is the usual average.

### **9.3 Age at First Breeding and Last Breeding**

Greater Stick-nest Rats become sexual mature at approximately 180 days in females and around 240 days in males. Little information is available on the age at which reproduction ceases, at ASDP reproduction reduced or ceased by 5 years of age with most individuals.

### **9.4 Ability to Breed Every Year**

Greater Stick-nest Rats can breed in consecutive years, dependent on group compositions and the age of individuals.

### **9.5 Ability to Breed More than Once Per Year**

Given the right conditions in a controlled environment Greater Stick-nest Rats will breed throughout the year with no distinct breeding season, however dependent on location and whether they are housed in outdoor facilities they have shown a peak in breeding during autumn and winter in temperate climates (<http://www.australianfauna.com/greatersticknestrat.php>). At ASDP breeding is not seen in this period possibly due to the extreme weather experienced at this time. Breeding at ASDP occurs from August through to March (in the spring-summer period).

### **9.6 Nesting, Hollow or Other Requirements**

When initially introducing a single animal into an enclosure a nest box, bin lids and browse should be provided. The nest box should be a minimum of 300mm x 300mm x 200mm with a 10cm diameter entrance hole. Space requirements should be strictly

adhered to during breeding as inadequate space and exceeding enclosure carrying capacity can cause cannibalism of young.

### **9.7 Breeding Diet**

Breeding animals are given the same diet as other stock, however when young are produced it is increased to allow for the lactational demand of the Dam and to coincide with the young's weaning and food requirements.

### **9.8 Oestrous Cycle and Gestation Period**

The oestrous cycle is approximately 14 days with gestation length of approximately 44 - 45 days. Young are weaned at 30-40 days. (Richards *et. al.*, 2001)

## **10 ARTIFICIAL REARING**

There has been no intensive hand rearing of Greater Stick-nest Rats. At Taronga Zoo, one Greater Stick-nest Rat was pulled at 42g and fairly well developed. Therefore all data used below is from a single individual and can not be considered definitive.

### ***10.1 Housing***

Initially the Greater Stick-nest rat was housed in a clear plastic insect box (70 x 40 x 50cm) with a ventilated roof. A fake 'nest' was provided such as a soft cotton bag inside a larger woolen one for the animal to retreat to. As the individual became more active a larger enclosure with climbing equipment was required to maintain health and fitness.

### ***10.2 Temperature Requirements***

A heat pad was provided at one end of the enclosure. Due to its age the individual was mobile and therefore able to determine its own proximity to the heat source.

### ***10.3 Diet and Feeding Routine***

Divitelac was used to rear the Stick-nest Rat. It was offered at room temperature from a bottle with a Ringtail Possum sized teat with a small needle hole in it. For the first 5 days the rat was provided 7.2 mL over 6 feeds. From day 6 to 8 the number of feeds was reduced to 4 per day. At day 9 the rat suddenly weaned and no longer required stimulation to defecate. From day 5 various hard foods were offered such as sprouted seed, greens, fruit, vegetables, nuts and dried seed. Browse such as saltbush can also be offered. Weaning will naturally occur between 30 and 40 days of age.

## **11 ACKNOWLEDGEMENTS**

I would like to thank the following people

- Wesley Caton for aiding in the collection of information within this manual and guiding me in its construction.
- Wendy Gleen for providing information on the hand rearing of Greater Stick-nest Rats in captivity.

## 12 REFERENCES

- Copley, P (1988) The Stick-nest Rats of Australia. A final report to World Wildlife Fund (Australia). Department for Environment and Planning, South Australia Government Printer, SA.
- Copley P (1999) Natural histories of Australia's stick-nest rats, genus *Leporillus conditor* (Rodentia: Muridae). *Wildlife Research*: **26**: 513-539.
- IATA (2007) *Live Animal Regulations*. International Air Transport Association, Montreal.
- Jackson, S.M. (2003) *Australian Mammals: Biology and Captive Management*. CSIRO Publishing, Melbourne.
- Moseby KE & Bice JK (2004) A Trail re-introduction of the Greater Stick-nest Rat (*Leporillus conditor*) in arid South Australia. *Ecological Management and Restoration*: **5 (2)**: 118-124
- Read, DG (1984) Diet and habitat preference of *Leggadina forresti* (Rodentia: Muridae). *Forestry Commission of New South Wales Technical Paper*. **58**.
- Richards, J., Copley, P. & Morris, K. (2001) The Wolpilkara's return. *Nature Australia: Aut 01*: 52-61
- Ryan SA, Moseby KE & Paton DC (2003) Comparative foraging preferences of the Greater Stick-nest Rat *Leporillus conditor* and the European Rabbit *Oryctolagus cuniculus*: Implication for regeneration of arid lands. *Australian Mammalogy*: **25**: 135-146.
- Strahan, R. 1995 (Ed.) The Mammals of Australia. Reed Books, Chatswood, NSW.
- [www.calm.wa.gov.au/plants\\_animals/pdf\\_files/sp\\_greater\\_stick-nest\\_rat.pdf](http://www.calm.wa.gov.au/plants_animals/pdf_files/sp_greater_stick-nest_rat.pdf)
- [www.environment.sa.gov.au/biodiversity/sticknestrat.html](http://www.environment.sa.gov.au/biodiversity/sticknestrat.html)
- [www.wildliferesearchmanagement.com.au/gsnr.htm](http://www.wildliferesearchmanagement.com.au/gsnr.htm)
- [www.aridrecovery.org.au/modules/content/index.php?id=12](http://www.aridrecovery.org.au/modules/content/index.php?id=12)
- [www.australianfauna.com/greatersticknestrat.php](http://www.australianfauna.com/greatersticknestrat.php)
- [www.sharkbay.org/jpg\\_images/sticknest\\_rat.jpg](http://www.sharkbay.org/jpg_images/sticknest_rat.jpg)

## 13 BIBLIOGRAPHY

- Bradley MP, Lambert C, Power V, Mills H, Gaikhorst, G & Lawrence C (1999).  
Reproduction and captive breeding as a tool for mammal conservation: The role of  
Modern Zoos. *Australian Mammalogy*: **21**: 47-54
- Copley, P (1988) The Stick-nest Rats of Australia. A final report to World Wildlife Fund  
(Australia). Department for Environment and Planning, South Australia  
Government Printer, SA.
- Copley P (1999) Natural histories of Australia's stick-nest rats, genus *Leporillus*  
*conditor*(Rodentia:Muridae). *Wildlife Research*: **26**: 513-539.
- Jackson, S.M. (2003) *Australian Mammals: Biology and Captive Management*. CSIRO  
Publishing, Melbourne.
- Moseby KE & Bice JK (2004) A Trail re-introduction of the Greater Stick-nest Rat  
(*Leporillus conditor*) in arid South Australia. *Ecological Management and*  
*Restoration*: **5 (2)**: 118-124
- Pedler, L., and P. Copley. (1993). Re-introduction of stick-nest rats to Reevesby Island,  
South Australia. Department of Environment and Land Management, Adelaide.
- Read, DG (1984) Diet and habitat preference of *Leggadina forresti* (Rodentia: Muridae).  
*Forestry Commission of New South Wales Technical Paper*. **58**.
- Richards, J., Copley, P. & Morris, K. (2001) The Wolpilkara's return. *Nature Australia*:  
**Aut 01**: 52-61
- Ryan SA, Moseby KE & Paton DC (2003) Comparative foraging preferences of the  
Greater Stick-nest Rat *Leporillus conditor* and the European Rabbit *Oryctolagus*  
*cuniculus*: Implication for regeneration of arid lands. *Australian Mammalogy*: **25**:  
135-146.
- Smith, A.P. & Quin D.G. (1996). Patterns and Causes of Extinction and Decline in  
Australian Conilurine Rodents. *Biological Conservation* **77**: 243-267
- Strahan, R. 1995 (Ed.) The Mammals of Australia. Reed Books, Chatswood, NSW.
- Watts CHS (1976). Notes on the Nests and Diet of the White-tailed Stick-Nest Rat  
*Leporillus apiculis* in Northern South Australia. *South Australian Naturalists*  
*Society*: **51(1)**: 9-13

[www.calm.wa.gov.au/plants\\_animals/pdf\\_files/sp\\_greater\\_stick-nest\\_rat.pdf](http://www.calm.wa.gov.au/plants_animals/pdf_files/sp_greater_stick-nest_rat.pdf)  
[www.environment.sa.gov.au/biodiversity/sticknestrat.html](http://www.environment.sa.gov.au/biodiversity/sticknestrat.html)  
[www.arkive.org/species/GES/mammals/Leporillus\\_conditor/more\\_info.html](http://www.arkive.org/species/GES/mammals/Leporillus_conditor/more_info.html)  
<http://www.wildliferesearchmanagement.com.au/gsnr.htm>

<http://www.aridrecovery.org.au/modules/content/index.php?id=12>  
<http://www.australianfauna.com/greatersticknestrat.php>  
<http://www.iucnredlist.org/search/details.php/11634/summ>

## 14 APPENDIX

### 14.1 Stocklist

<b>Brand</b>	<b>Product</b>	<b>Supplier</b>
<b>Baxter</b> One Baxter Drive Old Toongabbie NSW, 2146 AUSTRALIA (02) 9848 1111 <a href="http://www.oceania.baxter.com/">http://www.oceania.baxter.com/</a>	0.9% Sodium Chloride Fluids	Standard Vet Supplier
<b>Vetafarm</b> 3 Bye St. PO Box 5244 Wagga Wagga, NSW Australia, 2650 vetafarm@vetafarm.co.au www.vetafarm.com	AviSafe©	Standard Vet Supplier
<b>Nestle Purina Petcare (Friskies)</b> Level 6 123 Epping Rd North Ryde NSW, 2113 Australia (02) 8870 3800 www.purina.com.au	Pyrethrins Flea Powder	Standard Pet Shop
<b>Vetsearch</b> 15 Pritchard Place Peakhurst NSW 2210 Australia 1800 242 100	Cal-Plus	Standard Stockfeed Supplier
<b>International Animal Health Products Pty Ltd</b> PO Box 6199; Huntingwood NSW 2148 AUSTRALIA 02 9672 7944 www.iahp.com.au	Hardocks© Snow-E	Standard Stockfeed Supplier