

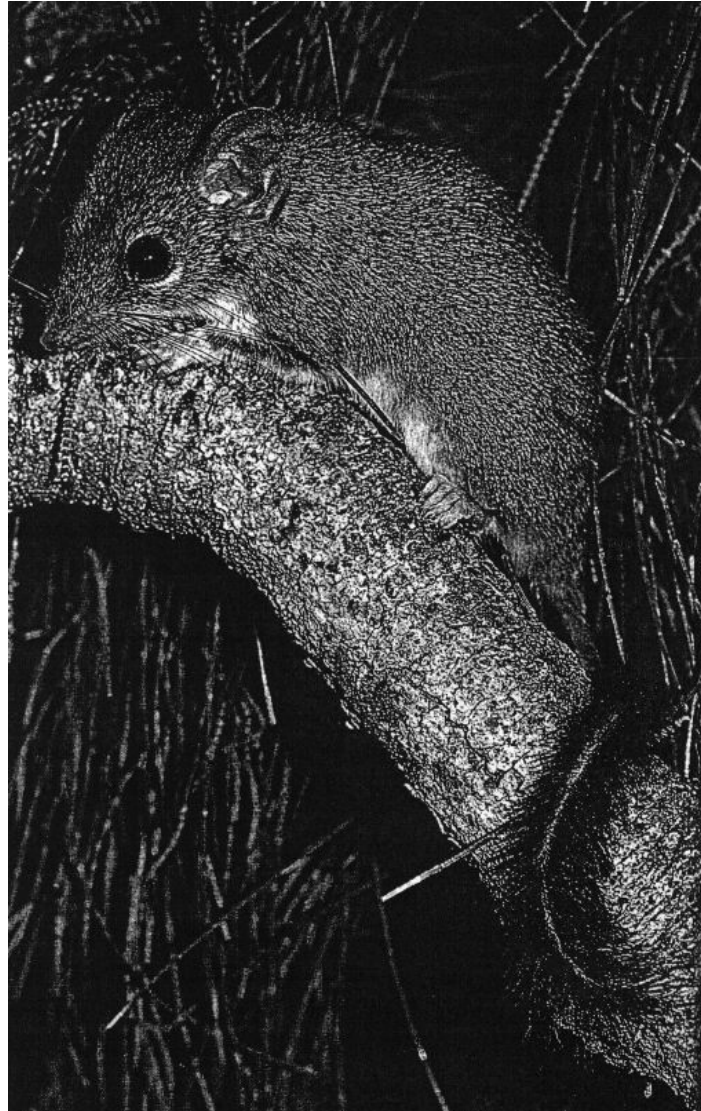

## Husbandry Guidelines

# Red-tailed Phascogale (*Phascogale calura*)



**Alice Springs Desert Park 2006**  
Compiled & Updated by Wes Caton

<b>CONTENTS:</b>	
<b>TAXONOMY.....</b>	<b>1</b>
Common Name.....	1.1
Classification.....	1.2
A.S.M.P. Category.....	1.3
I.U.C.N. Category.....	1.4
O.H.&S. Category.....	1.5
Studbook Keeper.....	1.6
<b>NATURAL HISTORY.....</b>	<b>2</b>
Family.....	2.1
Morphometrics.....	2.2
Wild data Table.....	2.2.1
ASDP Yearly captive & wild mean weights Table.....	2.2.2
ASDP Average male weight indicators Graph.....	2.2.3
ASDP Average female weight indicators Graph.....	2.2.4
Sexual dimorphism.....	2.3
Scent Glands.....	2.4
<b>DISTRIBUTION.....</b>	<b>3</b>
Habitat .....	3.1
Map.....	3.2
<b>BREEDING.....</b>	<b>4</b>
Gestation Period.....	4.1
Reproductive History .....	4.2
Growth & Development Diagram.....	4.2.1
Captive Reproduction.....	4.3
Litter Composition Table.....	4.3.1
ASDP Months of litters Graph.....	4.3.2
ASDP Yearly litter composition Table.....	4.3.3
Conspecific fostering.....	4.4
<b>CAPTIVE HUSBANDRY.....</b>	<b>5</b>
Overview.....	5.1
Housing requirements.....	5.2
Exhibit Furniture.....	5.3
Nestbox.....	5.4
Winter Nestbox Diagram.....	5.4.1
<b>CAPTURE AND RESTRAINT.....</b>	<b>6</b>
<b>DIET AND FOOD PRESENTATION.....</b>	<b>7</b>
Feeding Behaviour.....	7.1
Daily Captive Diet.....	7.1.1
Water .....	7.2
Daily Husbandry.....	7.3
<b>IDENTIFICATION.....</b>	<b>8</b>
<b>VACCINATIONS.....</b>	<b>9</b>

<b>KNOWN HEALTH PROBLEMS.....</b>	<b>10</b>
Ectoparasites.....	10.1
Endoparasites.....	10. 2
Toxoplasmosis.....	10. 3
Calcium Deficiency.....	10. 4
Tumours.....	10. 5
Male Die Off.....	10. 6
<b>TRANSPORTATION.....</b>	<b>11</b>
Transportation.....	11.1
Transportation Box Diag.....	11.1.1
Transportation Box.....	11.2
<b>REFERENCES.....</b>	<b>12</b>
<b>APPENDIX.....</b>	<b>13</b>
Yearly Timeline.....	13.1

# 1. Taxonomy

## 1.1 Common Name: Red-Tailed Phascogale

**Other Names:** Red-Tailed Wambenger

## 1.2 Classification:

**Class :** Mammalia

**Order :** Dasyuromorphia

**Superfamily :** Dasyuroidea

**Family :** Dasyuridae

**Subfamily :** Phascogalinae

**Genus Species :** *Phascogale calura* (Gould 1844)  
fas'-koh-gah-lay kah-lue-rah:  
'beautiful-tailed pouched weasel"

**Subspecies :** none

**Recent Synonyms :** none

## 1.3 A.S.M.P. Category: Population Management Program; Management Level 1b

## 1.4 I.U.C.N. Category: Endangered; ESP E

## 1.5 O.H.&S. Category: Non hazardous

## 1.6 Studbook Keeper: Gary Fry , 2004

# 2. Natural History

## 2.1 Family

Dasyurids are that group of marsupials that are mainly insectivorous or carnivorous. There are around 50 species of dasyurid in Australia. They also have some of the more complex reproductive strategies amongst Australian mammals. The Red-tailed Phascogale (*Phascogale calura*) is a small sexually dimorphic dasyurid weighing between 37 - 68 grams (Kitchener, 1981). The reproductive classification for the Red-tailed Phascogale is a Strategy I dasyurid (Lee *et al*, 1982) with sexual maturity at 11 months, seasonal breeding, semelparous, monoestrous and a gestation period ranging from 29-32 days (Foster, 2005). Today, conservation of the Red-tailed Phascogale relies on its persistence in a scatter of isolated, mostly small, remnant native vegetation plots in the southern part of Western Australia -[37 31 (S): 117 23 (E)] (Friend and Friend 1992).

In captivity at the Alice Springs Desert Park (ASDP)-[23 42 (S): 133 52(E)] the breeding season extends from May through to August. Environmental cues such as photoperiod, temperature and latitude are believed to influence the timing of births at ASDP, with the highest percentage of births occurring in July, (Graph 4.3.2 )(Caton, 2005). A maximum of 8 young can be accommodated in the female pouch though supernumerary young of up to a total of 18 are born (Taggart, pers.com.). The young are permanently attached to the teat for approx. the first  $42 \pm 4.3$  days and wean between 101 - 115 days (Caton, 2005).

In the month of May females enter oestrus over a 21 -24 day period (Bradley, 1997) and a synchronised ovulation of between four to five days duration occurs in each female (Foster, 2005). Foster

(2005) demonstrated that females utilise sperm storage with delays from four or five days up to periods of 19 days, which can provide the opportunity to influence the affects for multiple paternity.

As with many of the dasyurids, Red-tailed Phascogales are opportunistic feeders utilising a large variety of insects and spiders (Bradley 1995) though there is a preference for prey items less than 10mm in length. It is also known to take small vertebrates such as birds and mammals.

Current and continuing reproductive studies at ASDP with collaborative institutions have been beneficial in establishing and developing management strategies required for the long term captive sustainability of this endangered species.

## 2.2 Morphometrics:

Table 2.2.1 Wild Measurements WA

	Males	Females
Head and body length (mm)	105 – 122 (113)	93 – 105 (101)
Tail Length (mm)	134 – 145 (141)	119 – 144 (132)
Weight (g)	39 – 68 (60)	38 – 48 (43)

Adapted from Kitchener (1981)

Table 2.2.2 ASDP Yearly Captive & WA Wild Mean Weights

	Captive 2003	Captive 2004	Captive 2005	*Wild - WA
♂♂	46.58 ± 9.76 ( 38 - 62 ) n = 24	53.33 ± 9.11 ( 42.4 - 69.8 ) n = 24	57.94 ± 10.71 ( 43 - 73.66 ) n = 20	60 ± 4.4 ( 39 - 68 ) n = 6
♀♀	34.70 ± 5.71 ( 26.4 - 42.4 ) n = 28	35.12 ± 5.29 ( 28.33 - 39.66 ) n = 27	37.08 ± 4.79 ( 27 - 52 ) n = 27	42.5 ± 1.6 ( 37.5 - 48 ) n = 6

\*Kitchener (1981).

Graph 2.2.3 ASDP Average Male Weight Indicators

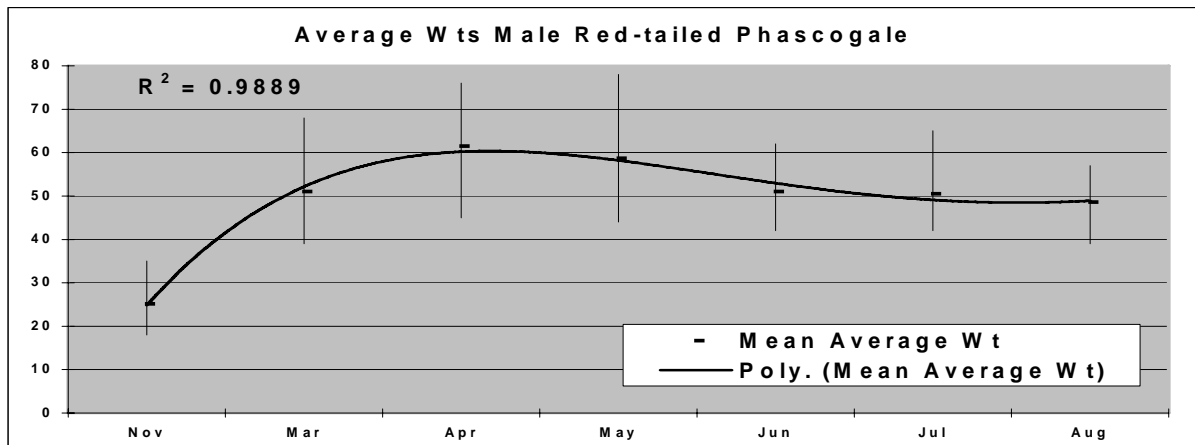

Graph 2.2.4 ASDP Average Female Weight Indicators

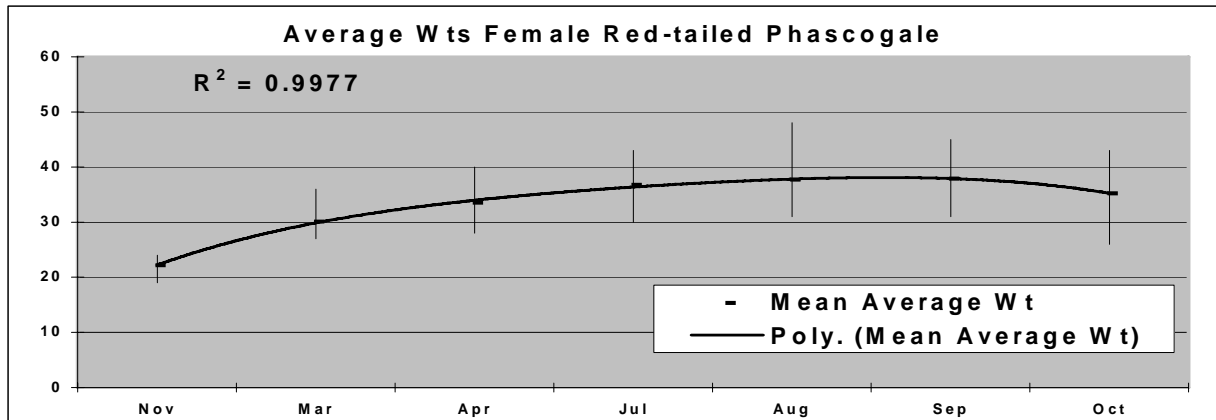

### 2.3 Sexual dimorphism

There is quite a marked size difference between the two genders upon reaching independence – the males are larger by a ratio of 1.38:1 (Bradley, 1997). The males have obvious testes; the females have a pouch and have up to 8 nipples (Bradley 1997).

### 2.4 Scent Glands

Males develop a prominent sternal gland from about 8 months of age - the fur becomes stained from around early June, and the skin becomes bare by the end of July (Bradley 1997), this gland is predominantly used for scent marking of their territory and advertising their presence during the breeding period. Bradley (1997) also reports that females produce a 'pleasant musk-scented white secretion from the paracloacal glands which was particularly noticeable during June and July.'

## 3. Distribution

### 3.1 Habitat

Kitchener (1981) describes in detail the vegetation type in which Red-tailed Phascogales were trapped. The animals were most often found in fairly dense growth that presumably provides cover as they move through their range. They weren't often found in tall trees where there wasn't dense understorey. Shrubs taller than 1.5 m were preferred.

It is noteworthy that the animals are often found in areas where *Gastrolobium* spp. and *Oxylobium* spp. dominate. These are the plants that produce monosodium fluoroacetate that is poisonous to sheep and cattle and foxes. The habitat Kitchener described also tended to be areas that had not burnt for some time and was thus more complex and provided numerous nesting sites, including hollow logs and trunks. Red-tailed Phascogales tend to avoid relatively open areas (Bradley, 1997).

In summary, the habitat Red-tailed Phascogales prefer to use has:

- ❖ A continuous vegetation canopy to assist movement through foliage
- ❖ A composition of older vegetation that has hollows for resting (Kitchener, 1981).

### 3.2 Map

#### 3.2.1 Locality Records of *Phascogale Calura* (Bradley 1997).

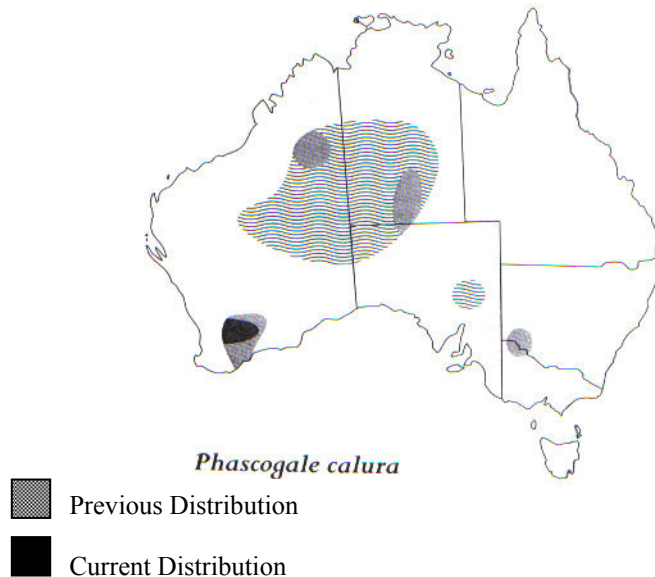

## 4. Breeding

### 4.1 Gestation Period

Gestation is 28 – 30 days (Bradley 1997)

### 4.2 Reproductive History

The Dasyuridae have a number of distinctive life history strategies (Lee, Woolley & Braithwaite 1982). Six strategies are described and *Phascogale calura* is a Strategy 1 species - monoestrous females, mating occurs during a highly synchronised period that is shorter than gestation, and males are semelparous, dying within two weeks of mating (Morton, Dickman & Fletcher 1989). Simply, this means that all mating occurs over a 21–24 day period in July (Bradley 1997) with all males dying by the end of July.

Gestation is 28 – 30 days (Bradley 1997) with females producing supernumerary young. Foster (2005) demonstrated that females utilise sperm storage with delays from four or five days up to periods of 19 days, which can provide the opportunity to influence the affects for multiple paternity.

Cuttle (1982) suggests that such a strategy is advantageous in that a female ensures that by producing as many young as she can at her one opportunity (within a year if not lifetime) she is minimising potential impact of high litter mortality during various stages of lactation. So whilst up to 13 young may be produced (n=18, Taggart, pers.com. 2005) a maximum of 8 can survive as the female Red-tailed *Phascogale* has a maximum of only 8 nipples.

As with other marsupial species, once the young has found the teat, the teat swells in the mouth effectively 'locking' the young to the teat for the first part of the period of lactation. It is difficult to remove the young from the teat at this stage without damaging the delicate mouth of the young. Red-tailed *Phascogales* first detach from the teat before 50 days ( $42 \pm 4.3$  days, Caton 2005), but Brush-tailed *Phascogales* *Phascogale tapoatafa* detach between 49 – 54 days (Cuttle, 1982).

**Diagram 4.2.1 Growth and Development of *Phascogale calura* in captivity (Caton 2005).**



\* Development from day 1 through to day 74.

Caton, 2005

#### **4.3 Captive Reproductive Breeding Strategy**

Offspring born in the year are segregated upon independence. This usually occurs around the month of October - November when the average weight range is from 17 - 26 grams and up depending on the sex of the individual and when they were conceived. At this period of time all juveniles can have a microchip inserted for permanent identification. Sexes are then divided into separate enclosures. Females may be housed in groups (depending on the size of the enclosure), and in relation to genetic compositions, though males must be housed as individuals. Aggression and injuries are very common amongst the males approaching maturity. Injuries can range from fur loss, multiple bite wounds to tail damage resulting in amputations or even death depending on the stress levels that they have been subjected to.

The reproductive strategy used for this species is to rotate individual males through the female's enclosure / s. This rotation of males provides competition and stimulation for breeding; this usually commences in May in timing with their natural breeding season. As an example a male would be introduced to the females enclosure on a Monday. After four days in the enclosure he would be removed on the Friday and the next selected male would be introduced to the enclosure. Most males on introduction to the enclosure will scent mark and explore the female scents immediately. They will go to the extent of climbing directly into the nestboxes for sniffing and exploration of the females. Introducing the new males is a straightforward process of release into the new enclosure. This is continued throughout the breeding season until females have produced pouch young.

With multiple females in an enclosure eg. 3-4 they may remain in the enclosure with pouch young whilst the rotations are carried out, provided that there are sufficient nestboxes. If by chance that a female hasn't produced pouch young towards the end of the season or by the time the first pouch young from other females are about to be left in the nest box, then either that female without pouch young or those with pouch young should be removed to another enclosure. This will also assist in aspects of genetic management. After all females are carrying pouch young and at the end of the breeding season, males naturally go through a die off stage.

Observations of matings were observed on numerous occasions. In typical Dasyuridae fashion the male would grasp the female from behind, around the base of the neck, to maintain a secure position for mating. Females behaviours indicated that they would dominate over the male for timing of mating before and after, though the males were usually very persistent with some females, indicating that the selected female may of been entering oestrus. Towards the end of the breeding season males exhibited hair loss over the rump region as well as numerous bite wounds through interactions with the females.

**Table 4.3.1 ASDP Litter Composition Breakdown 2002 - 2005**

Litter Size	1	2	3	4	5	6	7	8	TF	RF	#RP	Sex Ratio Outcome
2002				2	3	1	1	5	20	12		
2003		1		1		3	6	3	23	14		
2004					4	4	4	9	25	21	5	*30 : 41
2005	1	1	2	3	5	4	3	14	37	33	10	*64 : 67
Total n=	1	2	2	8	12	12	14	31				
P.Y %	1%	2%	2%	10%	15%	15%	17%	38%				

\* Breeding colony only

TF - Total female numbers including release pen stock & display

RF - Total females reproducing

Other reproductive strategies trialled with the Brush-tailed Phascogale (*Phascogale tapoatafa*) (Halley,1992) has been the introduction of a singular male to a female in May after being housed on their own, females produced young with an average of 5.1 (n=4). The success of this strategy relied on the timing of introduction.

The strategy used at the Alice Springs Desert Park for the Red-tailed Phascogale has produced an average of 7.4 (n=27) (Caton, 2004. unpub), this same strategy used on the Brush-Tailed Phascogale produced an average of 7.6 (n=5) (Halley, 1992). In captivity female Red-tailed Phascogales are capable of being reproductive >4 years, with litter compositions of 5 – 8 pouch young being produced consistently through to this age (Caton, 2004. unpub).

**Graph 4.3.2 ASDP Months of Litters Born 2002 - 2005**

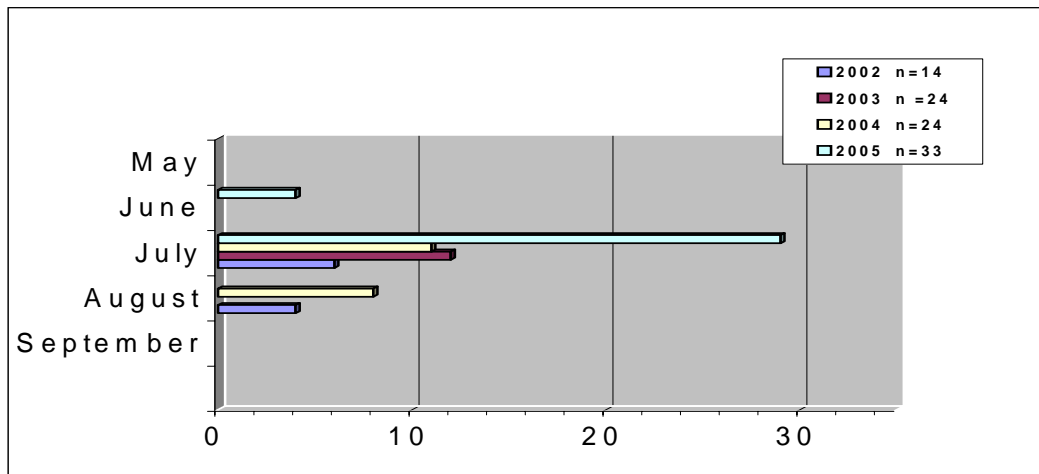

**Table 4.3.3 ASDP Yearly comparisons of litters born by month 2002 – 2005**

	2002	2003	2004	2005	Monthly %
May					
June				4	5
July	6	12	11	29	79
August	4		8		16
n = TF	20	23	25	37	

n = TF - Total females.

#### **4.4 Conspecific Fostering**

Conspecific fostering has been established in many dasyuid species. This technique has worked well with fostering genetically important individuals in crisis situations. The fostering is best carried out with animals ranging in development from first detachment of the teat to approx. 65 days of age. After this age period the fostering parent has been observed to repel, attack and kill the individual/s. This is most likely due to the unique scent of the new individual/s. Scent masking has been attempted with new individual/s but outcomes did not alter.

Fostering has been achieved with numbers of fostered individuals ranging from three to eight, whilst the fostering females were carrying between five and eight individuals of their own. All fostered stock were marked with a permanent marker for genetic identification and monitored for food intake along with the natural offspring (Caton 2004). Marking had to be replenished regularly as it faded quickly due to grooming.

Dependant on the species management program in place and the genetic requirements of the program, fostering may require the culling of surplus pouch young from a specific female as an individual or as part of a genetic managed group to provide the accomodation required for individuals with a higher genetic importance.

## **5. Captive Husbandry**

### **5.1 Overview**

The type of captive husbandry appropriate for animals that are part of the conservation program for Red-tailed Phascogales is to ensure that the human impact upon those animals that are in captivity is minimised as much as possible. This means that ideally the animal should not be aware it is captive. The microhabitat it encounters each night, the food for which it scavenges, the security it can seek, should all be, as much as possible, as would be encountered by the animal should it be in the wild.

There is compelling evidence from the work of a number of population geneticists working in this field that over a number of generations, a species can become more suited for living in captivity than was the case with those specimens first brought into captivity from the wild. It is therefore critically important that not only is the whole captive population managed conservatively and responsibly (the role of the PWCNT and CALM) but so too the individuals with respect to wild behaviour (the role of the animal husbandry practitioners.) It is necessary that animals do not imprint on humans and that they do not learn that there is a direct relationship between humans and food.

### **5.2 Housing Requirements**

A well-designed enclosure is more likely to result in animals exhibiting the full range of natural behaviours whilst enabling management of this species more effecient. An enclosure design pays heed to the species' natural habitat, behavioural needs, effective husbandry and animal security. It also needs to provide the animal with choices to stay dry or to bathe, to seek a cool area or a warm area, to scavenge and forage on the ground or to seek food amongst foliage.

Red-tailed Phascogales, are an arboreal and nocturnal species and are extremely good climbers. Facilities need therefore to be fully enclosed and secure. Galvanised wire mesh, with a 12mm<sup>2</sup> grid is suitable as a construction material to maintain this species, it is also important that the enclosure / exhibit

be measured in terms of volume rather than area due to their arboreal nature. Part of the enclosure roof should also be covered so that the animal can stay dry at all times. This species will dig so it is important that secure foundation such as concrete be provided.

Enclosures should be positioned so that the animals are able to avoid extreme temperatures and have a double door system. Simply, it ensures that at no stage when a door is opened is the animal able to escape. If the animal does move past the keeper through the enclosure door, the safety porch contains it. Red-tailed Phascogales are very swift and will easily move past a person in a doorway. Enclosures also should have doors large enough that exhibit furniture can easily be added and removed.

In winter, nest boxes with appropriate amounts of nesting material are sufficient to keep animals warm in temperate climates, in cooler climatic zones artificial heating may be required or insulated nestboxes that have proved to be beneficial are recommended. In summer, it will be necessary to keep animals protected from extreme temperatures, micro mist system irrigation and shade cloth structures with an air space of 30cm overhanging the enclosures assist to drop internal temperatures by up to 7°C when the ambient temperatures reach between 35 - 45°C.

### 5.3 Exhibit Furniture

The substrate of the enclosure should encourage the animals' natural behaviours. As has been shown, Red-tailed Phascogales will consume a large number of terrestrial invertebrates. The provision of native leaf litter to a depth of about 100mm should provide sufficient hiding places for invertebrates, this depth will also assist this species in extreme temperatures as they will dig and submerge themselves in the cooler environment provided.

Large vertical perching should be installed into the enclosure; these can be of any thickness ensuring that the perching is secured in place. Perching should span large portions of the enclosure / exhibit to provide passageways for this species to traverse from nestboxes to water and feed bowls with ease. Native timber will also assist in claw growth reduction. Providing and replenishing large browse regularly will stimulate and enrich the animals as well as provide them with protection, security and the opportunity to forage (in accordance with breeding schedule). The furniture in the enclosure should be native timber to avoid any risk of toxicity and allows new materials to be easily obtained.

### 5.4 Nest Box Design

At least one nestbox per pair should be provided; if multiple animals are being housed together than a ratio of one box per two animals should be incorporated. eg. 5 animals / 3 nestboxes. Nestboxes (150x150x150mm) should be provided in numerous locations throughout the enclosure, ensuring that protection from the weather is provided.

#### 5.4.1 Photos of Winter Nestbox



Foam insert with internal box.

Marine ply construction, and 40mm pvc pipe as entry hole into insulated box.



An overhang is required on the lid for added protection from the sun and rain for those boxes exposed to the weather. The overhang allows for a greater shade area over the box. The lid should be sloped to keep rain out and reflect some of the heat.

The box should be made of a marine ply and be painted to seal the timber and make it water-resistant. The lid should be hinged for ease of cleaning. It is necessary to have a spare nestbox as they are soiled continuously through faecal and food waste contamination. It ensures that animals always have a box available even when one is being cleaned.

The nesting material should be checked on a weekly basis to ensure that it has not become too wet / soiled. If the material needs to be changed, a second box complete with nesting material should be set up within the enclosure, the animal encouraged to relocate to the new nest box, and the old one removed and cleaned.

The next box is ideally hung on a wall under cover and usually as high in the enclosure as the keeper can comfortably reach. There needs to be branches leading to the entrance hole so that the animals can enter and leave the nest box easily. The nest box is filled with a nesting material of either shredded paper, dried grasses or leaf litter. The box should be loosely filled so that the animal may construct its own nesting hollow / drey. It may be that the animals will also gather natural nesting material from within the enclosure. Native grasses etc. should be provided.

## **6. Capture and restraint**

A good nest box includes a slide over the animal's entry hole so that the animal can easily be trapped inside the nestbox for retrieval. It is considerably easier to restrain an animal in a nest box than it is to catch an animal from within an enclosure using a net. Moreover, there is far greater likelihood of damage to the animal utilising the latter method. Animals can be removed from the nestbox in numerous ways depending on the experience of the keeper and more so the number of animals in the box.

If the animal needs to be transferred to a calico bag from the nest box, a bag can be placed over the side of the box at the entrance hole. The animal is then encouraged to leave the nest box; tapping at the end of the box opposite to the entrance and tipping the box up may be sufficient. Once the animal is in the bag, the neck of the bag can be closed and tied securely. Another method of retrieving the animal from the box is to place your hand into the reversed calico bag (seams inside of bag), gripping the animal gently and securely around the base of the head and then reverting the bag over it. Once the animal is in the bag, the bag can be tied, now that it is secure and the animal can be weighed. For further observations and health checks the animal can be restrained by placing your hand flat on the bag, grasping the animal in the same grip as before and peeling back the bag over the head or body, depending on which area is to be examined. Animals should not be left in calico bags for long periods, as they will readily chew out. Animals left unattended when in a calico bag should always be held in a secure box.

Capture and manual restraint should only take place during the coolest part of the day. Stressed animals are less able to control body temperature and fatalities can result.

Phascogales can inflict a nasty bite. As with all animals, any bites and scratches should receive first aid treatment.

## **7. Diet and food presentation**

### **7.1 Feeding Behaviour**

Kitchener (1981) lists diet items from nine different arthropod orders. It seems though that cockroaches and beetles are favoured food items. Hair samples that were analysed from the stomach contents of some Red-tailed Phascogales were from species including feral mice *Mus musculus* and European Rabbit *Oryctolagus cuniculus*, the latter being juvenile and presumably found dead by the phascogale. The large number of grasshoppers, cockroaches and beetles in stomach contents also indicate that the Red-tailed Phascogale spends some time foraging on the ground.

Red-tailed Phascogales will feed on a wide variety of insects. It is preferable to feed wildlife on as natural a diet as possible for a multitude of reasons. Broadly speaking, presentation of a natural diet will ensure that nutritional and behavioural needs are covered as much as possible.

### **7.1.1 Daily Captive Diet. Alice Springs Desert Park**

#### **Red-tailed Phascogales**

Monday	Crickets	15g
Tuesday	Adult Mouse (Cal. & Vit-E dusted)	15g
Wednesday	Crickets	15g
Thursday	Roaches	15g
Friday	Mealworms	15g
Saturday	Insects (Mix)	15g
Sunday	Pinkies (Cal. & Vit-E dusted)	15g

Insects are fed either live or dead and in such a manner that ensures if fed live, that they can't escape the enclosure. All other food is presented in a clean plastic bowl or dish. If there are problems with ants in the enclosure, food dishes can be sat in a shallow dish of water to deny ants access to the food. Animals should be fed as late in the day as possible to ensure that food is still in optimum condition (it has not been spoiled by the sun or heat) when the animal eats.

#### **❖ Special dietary requirements**

Females when either pregnant or lactating will have greater energy demands than other times of the year. Sub-adult animals, which are growing, will also have large appetites. One can expect animals to eat more in cooler weather than in warm – more energy is involved in maintaining body temperature. Average food quantities for females with pouch young increase from an average of 15g daily and progress up to 30g daily prior to pouch young's independence at approx. 75 days. Individual food consumption and variance in food selection is common in this species and notable prior and throughout the breeding season.

### **7.2 Water**

Water is provided *ad libitum* in shallow dishes and usually best presented on the floor, though many animals are used to drinking from water trapped in tree hollows. Water can also be presented in water bottles with a stainless steel ball drip feeder (Rat & Mouse water bottle). Animals quickly learn to use these; though daily checking is required to ensure that the ball in the dispenser is free moving and operational as mineral build up can effect its operating capabilities.

### **7.3 Daily Husbandry**

Enclosures should be cleaned on a daily basis to avoid a build-up of faecal material.

- Removal of all uneaten food.
- Cleaning - raking the floor / wiping down shelves & the tops of nestboxes , scrubbing or hosing down wire and perching.
- Animal should be sighted every second day (dependant on breeding status). Should no food be consumed, then the animal should be checked.
- Water supply should be checked and replenished daily.
- The integrity of the enclosure should be checked.
- Food provided in a clean dish as late in the day as possible.

#### **Weekly Husbandry**

- Water bottles and feeding utensils soaked / sterilised
- Fresh browse added ad lib

- ❑ Nestboxes changed over and cleaned weekly
- ❑ Replenish substrate mulch
- ❖ Substrate fully changed and replenished between breeding seasons
- ❖ Cleaning of equipment with detergent and water, then rinsed and sprayed with Avisafe® - Halogenated Tertiary Amines at a rate of 1:100ml

## 8. Identification

Almost all animals in programs with a captive component have a unique identifier. In the case of Red-tailed Phascogales, the animals are implanted interscapularly (between the shoulder blades) with a Trovan™ microchip. When applying the microchip to juveniles Vetbond™ (a tissue adhesive) is used to secure and bind the opening. This is usually carried out once the individuals reach a weight of approx. 20 grams. Other means of identification can be punch holes numerically positioned around the ears, metal eartags or tattooing along the ventral surface of the tail base or ears.

All correspondence and records should refer to this unique identifier.

## 9. Vaccinations

NONE

## 10. Known Health Problems

### 10.1 Ectoparasites

Ectoparasites in dasyurids include fleas, ticks and mites (Booth 1994; Cunningham 1994; Woolley 1982). The flea, *Uropsylla tasmanica*, has been reported in thylacines, Tasmanian devils, eastern quolls and spotted-tailed quolls where heavy infestations have been recorded in the distal limbs, ears, groin, scrotum and face which can cause considerable irritation and result in severe scratching and hair loss (Obendorf 1993). The number of ectoparasites can be greatly reduced or eliminated by changing the nest material and washing the nest boxes frequently (Woolley 1982). They can also be controlled using Carbaryl topically or Ivermectin 1% injectable (200mcg/kg subcutaneously).

Mite infestations have been known to occur after their transfer from laboratory rodents used as food (Woolley 1982). These have been treated with the sarcopticide Tetmosol (ICI) diluted 1: 15 with water and drenching the dasyurids in this (while anaesthetised), however this has led to several deaths, so the feeding of rodents with mites is not recommended (Woolley 1982). Most species of dasyurids appear to undergo an annual moult, particularly after the breeding season (Woolley 1982).

### 10.2 Endoparasites

Various species of endoparasites have been found in dasyurids including nematodes (eg. Ascarids, *Strongyle* spp. and *Trichinella spiralis*) and cestodes (eg. *Taenia ovis* and *Anoploetaenia*) (Cunningham 1994). In wild populations, antechinus have been found to carry numerous species of endoparasites which rise sharply during the breeding season in males, compared with females, and are considered directly involved with the seasonal mortality of males (Beveridge & Barker 1976).

### 10.3 Toxoplasmosis

*Toxoplasma gondii* has been observed in kowari, antechinus, dunnarts, mulgara and kultarr and has caused significant mortality in captive populations (Attwood & Woolley 1972; Obendorf 1993). Affected animals show a variety of abnormalities including altered behaviour, blindness, incoordination, paralysis or death without prior symptoms (Obendorf 1993). Clouding of the cornea or lens of one or both eyes and destructive retinochoroiditis has also been observed in several kowaris and a white-footed

dunnart (Attwood & Woolley 1982). Other signs of infection include difficulty in walking and can drag one or both hind limbs and show signs of meningomyelitis (Attwood & Woolley 1982).

High incidences of toxoplasmosis via the protozoan *Toxoplasma gondii* has been found to occur due to raw sheep meat in the diet so unless the meat is frozen for several weeks, which appears to reduce the infectivity of *Toxoplasma* cysts its use is not recommended (Dubey 1974; Woolley 1982; Attwood *et al.* 1975; Attwood & Woolley 1982).

#### **10. 4 Calcium Deficiency**

Animals fed only meat can suffer from calcium deficiency, so additional calcium in the form of calcium carbonate can be added to meat preparations (Woolley 1982). Raw meat is dusted with calcium at approx.2mg per raw meat feed.

#### **10. 5 Tumours**

Tumours have frequently been observed in dasyurids in captivity (Attwood & Woolley 1973; Reece & Hartley 1994). Neoplasia (abnormal growth of tissue) is frequently observed in the deaths of dasyurids in captivity (Attwood & Woolley 1973), with tumours observed including lymphatic, haemangiomas, heptacellular carcinomas, osteosarcomas, mesotheliomas, melanosarcomas, fibrosarcomas, medulloblastomas, pulmonary adenomatosis, lymphosarcoma, lymphatic leukemia mammary and cutaneous tumours and papillomas (Arundel *et al.* 1977; Reece & Hartley 1994).

#### **10. 6 Male Die Off in Antechinus and Phascogales**

Antechinus and phascogales are unusual in that after mating in the wild all the males die off, which is termed semelparity (Braithwaite & Lee 1979). The deaths generally result of an increase in plasma corticosteroids and adrenal weight, a decrease in body weight, negative nitrogen balance, gastrointestinal haemorrhage, marked neutrophilia and lymphopenia, anaemia associated with heavy parasitaemias by *Babesia* sp. and high immunosuppression (Arundel *et al.* 1977; Barnett 1973; Barker *et al.* 1978; Braithwaite & Lee 1979; Lee & Cockburn 1985; Lee *et al.* 1977). In captivity the males generally live for more than one year, up to four if unmated, though they generally have testicular failure and are sterile (Halley 1992). Males also show parasitism by a range of internal and external parasites, with a higher prevalence of infection with some nematodes in males during the breeding and post-breeding period (Arundel *et al.* 1977).

## **11. Transport**

### **11.1 Transportation**

Transport is ideally undertaken either in an air-conditioned motor vehicle or by air. With any mode of transport, care should be taken to ensure that stress is kept at a minimum. Provide a quiet and comfortable environment from the moment the animal is placed in its transport box to the moment it is placed safely in its new enclosure. A comfortable temperature for travelling would be between 18 - 25°C. Whether the animal travels by day or night a number of factors need to be taken into consideration: duration of the trip, temperatures to be encountered, mode of transport and period of time in between and where will they be kept.

### 11.1.1 Transportation Box

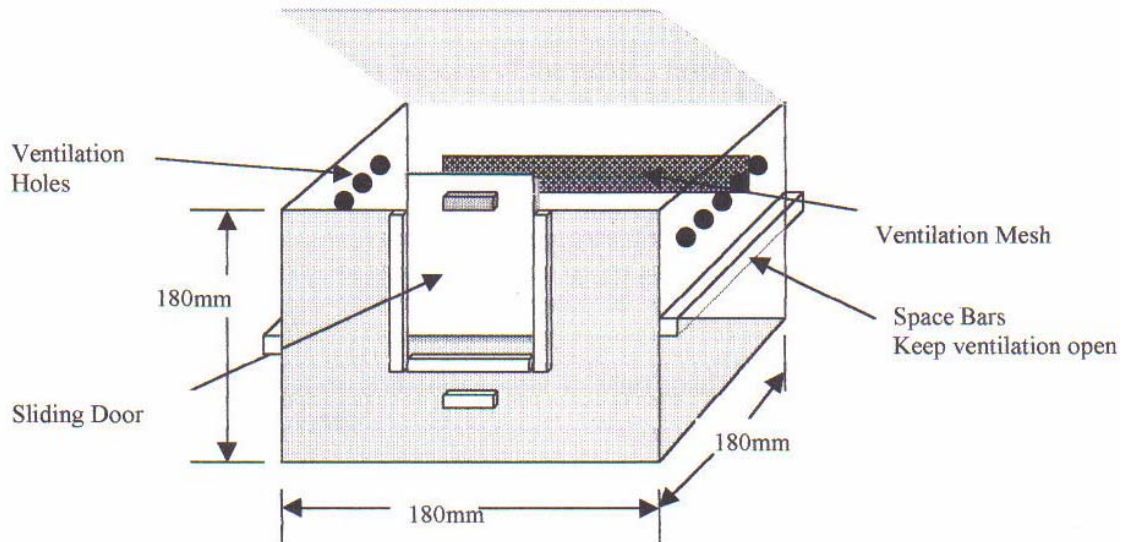

### 11.2 Transportation Box

A wooden box with a sliding door is the most satisfactory method of transporting phascogales. The box must have adequate ventilation, either with drilled holes or a wire mesh panel. The wire mesh panel can be covered with hessian to reduce light and noise. Ensure there is a smooth finish inside the box, no splinters of wood or wire ends. Ensure that the locking devices are adequate, barrel bolts or a sliding door that screws shut. The box should comply with IATA regulations. Figure 11.1.1

Some form of nesting material is required: hay, sea grass or shredded paper. Loosely  $\frac{3}{4}$  fill the box with the material and make a depression in the middle to accommodate the animal / s. Females may be housed in groups depending on box sizes, though males should be housed individually for transportation.

Transporting females with young should be avoided whenever possible until the young are weaned, this will prevent any from being thrown or lost during transport. It is not necessary to provide food or water during transfers over short distances.

## 12. References

Attwood H D and Woolley P A 1979 Histopathology of captive dasyurid marsupials. The Management of Australian Mammals in Captivity, ed by D D Evans. Zoological Board of Victoria pp 27 - 30

Booth R 1994 Medicine and husbandry: Dasyurids, possums and bats. pp 423-41. In Post Graduate Committee in Veterinary Science (ed) *Wildlife*. Proceedings 233. Post Graduate Committee in Veterinary Science, University of Sydney, Sydney.

Bradley A J 1987 Stress and mortality in the red-tailed phascogale, *Phascogale calura* (Marsupialia: Dasyuridae). *General and Comparative Endocrinology* 67: 85 - 100

Bradley A J Red-tailed Phascogale in Strahan R ed 1995 *The Australian Museum complete book of Australian Mammals* Reed Books, NSW pp 102 - 103

- Bradley A J 1997 Reproduction and life history in the red-tailed phascogale, *Phascogale calura* (Marsupialia: Dasyuridae): the adaptive-stress senescence hypothesis *Journal of Zoology* (London) 241: 739 – 755
- Caton W 2005, The Real Deal The Good Stuff Mothers Milk: You Cant Beat It Thylacinus Vol.29 no.2 2005 pp 2 -4.
- Caton W 2006, Growth and Development of the Red-tailed Phascogale (*Phascogale calura*) in captivity. Thylacinus Vol.30 no.3 2006 pp 2 -7.
- Caton W 2005 Captive maintenance and breeding of the Red-tailed Phascogale (*Phascogale calura*) at the Alice Springs Desert Park. Thylacinus. (to be published )
- Cuttle P 1982 Life history strategy of the dasyurid marsupial *Phascogale tapoatafa* in *Carnivorous Marsupials* ed M Archer, Royal Zoological Society of NSW, pp 13-22
- Foster W.K, Bradley A. J, Caton W, Taggart D.A, Comparison of growth and development of the red-tailed phascogale (*Phascogale calura*) in three captive colonies *Australian Journal of Zoology* 54, pp1-10
- Halley M 1992 Maintainance and captive breeding of the Brush-Tailed phascogale: Zoo Int Yb.(1992) 31:P 71-78
- Kitchener D J 1981 Breeding, diet and habitat preference of *Phascogale calura* (Gould 1844) (Marsupialia: Dasyuridae) in the southern wheat belt, Western Australia *Rec. West. Aust. Mus.* 9(2): 173 – 186
- Lee A K, Woolley P A and Braithwaite R W 1982 Life history strategies of Dasyurid marsupials in *Carnivorous Marsupials* ed M Archer, Royal Zoological Society of NSW, pp 1-11
- Morton S R, Dickman C R and Fletcher T P 1989 Ch 21 Dasyuridae in *Fauna of Australia: Mammalia* ed D W Walton and B J Richardson Australian Government Publishing Service, Canberra pp 560 – 582
- Rhind S G, Bradley J S and Cooper N K 2001 Morphometric variation and taxonomic status of brush-tailed phascogales, *Phascogale tapoatafa* (Meyer, 1793) (Marsupialia : Dasyuridae) *Australian Journal of Zoology* 49 (4) pp 345 - 368
- Spencer P B S, Rhind S G and Eldridge M D B 2001 Phylogenetic structure within *Phascogale* (Marsupialia : Dasyuridae) based on partial cytochrome *b* sequence *Australian Journal of Zoology* 49 (4) pp 369 - 378
- Strahan R ed 1995 *The Australian Museum complete book of Australian Mammals* Reed Books, NSW

### 13. Appendix

#### 13.1 Yearly Work Schedule for Red-tailed Phascogale Colony

January	<ul style="list-style-type: none"> <li>➤ Diet; 15g per individual</li> <li>➤ Substrate changes</li> <li>➤ Enclosure preparations, perching etc.</li> <li>➤ Breeding plan reviewed</li> <li>➤ Separate stock as / if required</li> </ul>
February	<ul style="list-style-type: none"> <li>➤ Prep tubs &amp; nestboxes</li> <li>➤ Diet; 15g per individual, 10g per tub</li> <li>➤ Nesting material collection</li> <li>➤ Enclosure allocation plan for breeding</li> <li>➤ Notices and enclosure rotations updated</li> <li>➤ Set up breeding stock in allocated positions</li> </ul>
March	<ul style="list-style-type: none"> <li>➤</li> <li>➤ New browse</li> <li>➤ Enclosure notices / rotations schedule</li> <li>➤ Winter nestboxes for enclosures</li> </ul>
April	<ul style="list-style-type: none"> <li>➤ Cleaning of walls</li> <li>➤ Substrate replenish</li> <li>➤ Nestbox substrate changes</li> <li>➤ Notify staff of plan</li> </ul>
May	<ul style="list-style-type: none"> <li>➤ Minimal disturbance</li> <li>➤ Start breeding rotations 1st week</li> </ul>
June	<ul style="list-style-type: none"> <li>➤ Rotations as required</li> <li>➤ No unnecessary disturbance</li> </ul>
July	<ul style="list-style-type: none"> <li>➤ Pouch checking in 1<sup>st</sup> week</li> <li>➤ Breeding of remaining stock</li> </ul>
August	<ul style="list-style-type: none"> <li>➤ Breeding of remaining stock</li> <li>➤ Diet increases – females with p.y</li> </ul>
September	<ul style="list-style-type: none"> <li>➤ Diet increases – females with p.y</li> <li>➤ Breeding complete</li> <li>➤ Management of male stock 1st week</li> </ul>
October	<ul style="list-style-type: none"> <li>➤ Diet increases – females with p.y</li> <li>➤ Diet; 15g per individual, approaching weaning</li> </ul>
November	<ul style="list-style-type: none"> <li>➤ Trovaning juveniles &gt; 20 grams / weaning</li> <li>➤ Records updating – B/H</li> <li>➤ Studbook update</li> <li>➤ Management of female stock &amp; surplus</li> </ul>
December	<ul style="list-style-type: none"> <li>➤ Studbook recommendations for following year</li> <li>➤ Management of surplus stock</li> <li>➤ Diet; 10 g per individual</li> </ul>